

Inquiry form specific quotation

Page 1 from 2

mimatic®

Tool Systems

Inquiry date:

Duty date:

Quotation No.:

Customer No.:

Company:

Phon:

E-Mail:

Contact person:

Fax:

Machining:

Milling:

Turning / countersinking:

Project:

Work piece description:

Customer-ID-No.:

Work piece drawing:

Amount per month / year:

Machining allowance: yes no

Workpiece clamping fixtures:

Tool clamping fixtures:

Tool unclamping lenght:

Material:

Strength / hardness:

STEP-File:

yes

no

Tolerances:

→if yes:

mm

Clamping diameter:

mm

Operational conditions groove shape:

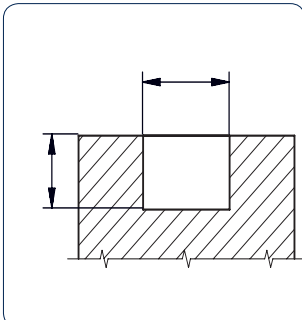

basic geometry

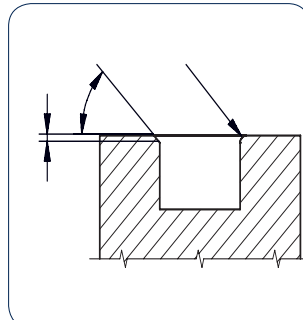

chamfer/radius

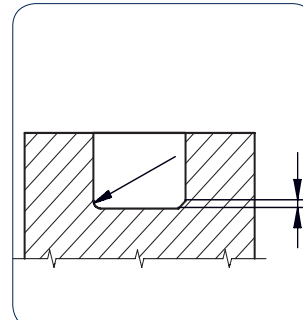

corner chamfer/radius

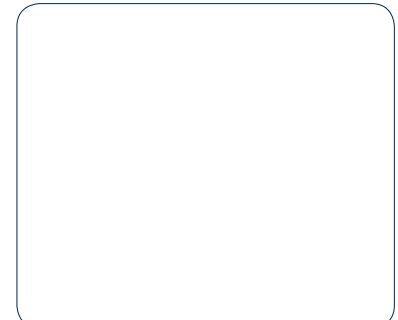

special shape

Groove straight / radial:

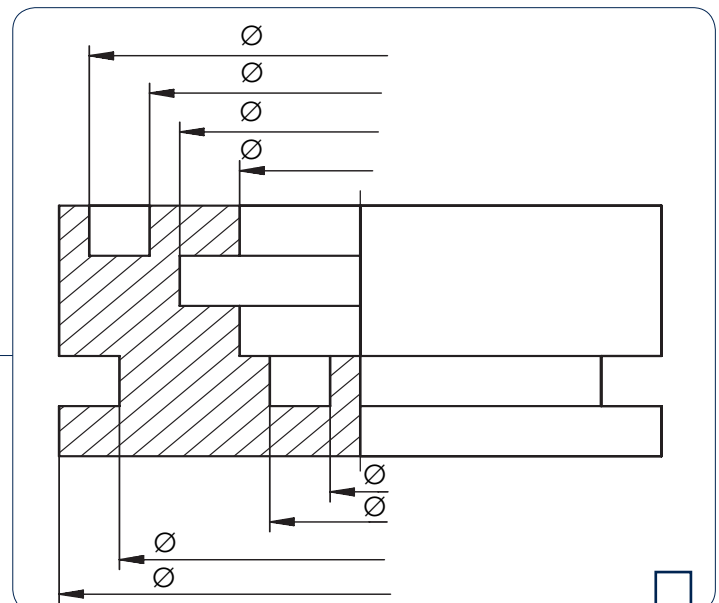
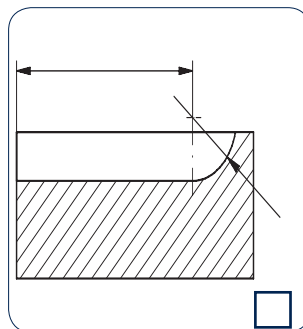
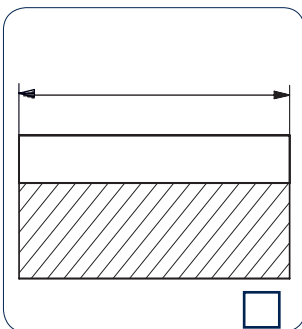

Radial- / Face- / outside- / inside- ∅
please enter dimensions for the desired application

Draw in → jaw chuck / revolver / tool clamping

Single production:

New process:

max. tool expenses (optional):

Mass production:

Optimize:

Notes, comments, more Info:

Sketch: